

# Accu-Lube<sup>®</sup>

## User's Manual

*Installation & Operating Instructions*

# PRECISION PUMP APPLICATOR

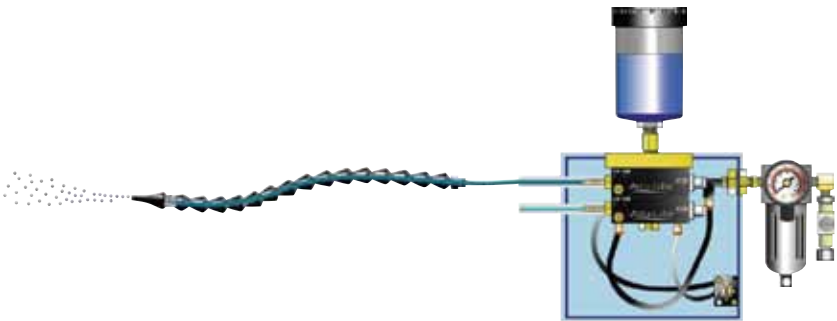

For Box, Junior, and Custom Applicators

For questions and/or product support contact the ITW ROCOL North America  
Customer Service Department at (847) 657-5278 ext. 2.

# INTRODUCING ACCU-LUBE

## *History of Excellence*

Since 1979 Accu-Lube has been the industry leader in manufacturing lubricants and equipment for Minimum Quantity Lubrication (MQL). Today Accu-Lube continues to be at the forefront of MQL and near-dry machining through a dedication to innovation, safety, and service.

## *Quality over Quantity*

Accu-Lube MQL precision pump applicators use advanced technology to focus droplets of lubricant directly onto the tool's cutting edge, providing lubrication and protection precisely where it is needed. This minimum quantity approach allows manufacturers to conserve fluid and cut down on waste. By eliminating unneeded flood coolant shops remain clean and fluid maintenance is no longer necessary. This process is called Near-Dry Machining.

## *ITW ROCOL North America*

ITW ROCOL North America, manufacturer of Accu-Lube products, is an industry leader in the development and production of scientifically advanced fluid products for the metalworking industry.

# PRECISION PUMP APPLICATORS

Accu-Lube Precision Pump Applicators are positive displacement lubrication systems for Minimum Quantity Lubrication that regulate the amount lubricant applied to a tool's cutting edge in exact quantities.

Accu-Lube precision pumps are designed to accurately deliver a constant and consistent amount of lubricant from the instant the applicator is turned on until the moment it is turned off. Unlike cheap siphon-type imitators, which are negatively affected by small variances in air pressure, room temperature, air hose length, and lubricant viscosity, Accu-Lube precision pumps operate with accuracy and precision year after year to deliver lubricant to the cutting edge each time, every time.

An Accu-Lube precision pump uses positive displacement and air pressure to power the pump cycle. The back stroke of the cycle draws a precise, measured amount of lubricant into a chamber like a syringe. Instantly the forward stroke forces the lubricant down a capillary tube inside an air hose up to 60 ft. (18 m) long. Since the pump cycle is automatically regulated by a frequency generator it is not affected by lubricant viscosity, which changes with temperature. This is crucial for any application operating in an environment without climate control since lubricants thicken in the cold. Accu-Lube precision pumps deliver instant performance, with every type of Accu-Lube lubricant, in all conditions.

# TABLE OF CONTENTS

Components .....	4
Preparing .....	5
Installing .....	6
Nozzle Positioning .....	6-7
Operating.....	7
Setting the Lubricant Control.....	8-9
Setting the Frequency Generator .....	10
Re-Priming the Pump.....	10
Replacing the Hose Assembly .....	11
Replacement Parts.....	12-13
Warranty.....	13
Troubleshooting .....	14
Technical Support .....	14

# UNPACKING & INSPECTING

Before beginning set-up make sure that you have the following items:

1. Accu-Lube precision pump applicator (Box, Junior, or Custom Applicator)
2. Liquid reservoir
3. Nozzles and mounting clamps (if applicable)
4. 8 oz. LB-2000 sample
5. Warranty card, fill out and return within 10 days of purchase

If one of these items is missing do not continue with set-up. Contact Customer Service at (800) 452-5823 ext.2 regarding missing/damaged items.

# COMPONENTS

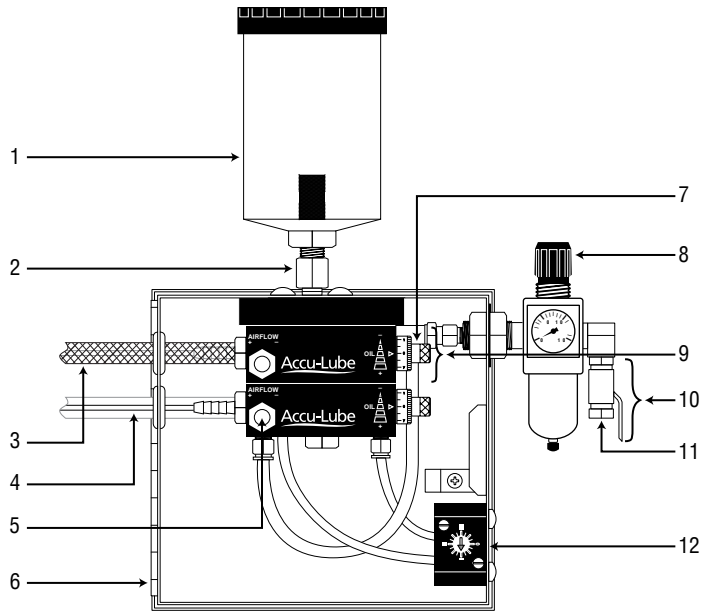

Figure 1. Two Nozzle Aluminum Pump Applicator with Manual Control

1. **Liquid Reservoir:** Lightweight, durable polycarbonate reservoir (several sizes and designs are available, see page 12 for information).
2. **Reservoir Extension:** Connects the liquid reservoir (#1) to the applicator.
3. **Braided Air Hose:** Carries compressed air to the nozzle.\*
4. **Lubricant Line:** Capillary tube that runs inside the braided air hose.\*  
\*Hose Assembly: braided air hose (#3) & lubricant line (#4).
5. **Airflow Valve:** Controls the amount of continuous air supplied to the nozzle.
6. **Security-Box (Box & Custom Applicators only):** Durable steel box with lock. Separate front and back doors offer maximum access and protection.
7. **Lubricant Control:** Secondary lubrication control; adjusts the amount of lubricant delivered during each pump cycle.
8. **Air Filter Regulator/Pressure Gauge:** Helps prevent particles and water from entering the applicator through the air supply.
9. **Precision Pump:** Uses air pressure to power the pump cycle; provides consistent and accurate lubrication instantly.
10. **On/Off Valve (Manual applicators only):** Controls the applicator by regulating airflow (electronic solenoid controls are available, see page 12 for information).
11. **Air Inlet:** Accu-Lube precision pump applicators are pneumatically powered.
12. **Frequency Generator:** Primary lubrication control; regulates the pump cycle.

# PREPARING

1. Remove the plastic shipping plug from the reservoir extension (Fig. 1 #2) on the top of the applicator and clean any debris from the threads and opening.
2. Wrap the threads on the bottom of the reservoir (Fig. 1 #1) with Teflon tape (not included) and attach to the reservoir extension with a  $\frac{3}{4}$ " wrench.
3. Connect the nozzle to the end of the hose assembly:

## Copper/Stainless Steel Nozzle:

- a. Cut the lubricant line so that it will stop  $\frac{3}{4}$ " to  $1\frac{1}{2}$ " from the end of the nozzle when the tip is installed.\*

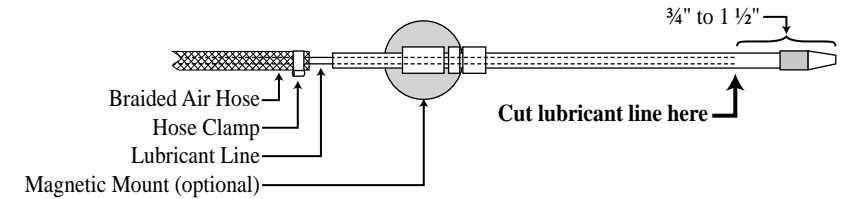

- b. Slide the hose clamp onto the air hose. Insert the end of the nozzle 1" into the air hose. Slide the clamp  $\frac{1}{2}$ " from the end of the air hose and secure.

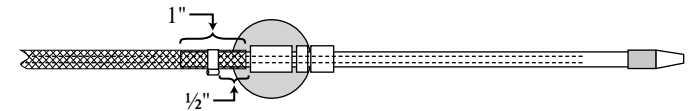

## Loc-Line Nozzle:

- a. Cut the lubricant line back to the third knuckle from the nozzle tip.\*

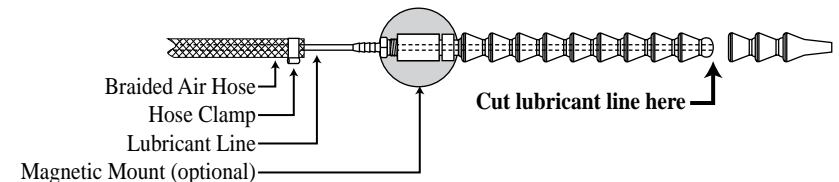

- b. Slide the hose clamp onto the air hose. Insert the end of the nozzle into the air hose. Slide the hose clamp over the air hose and secure.

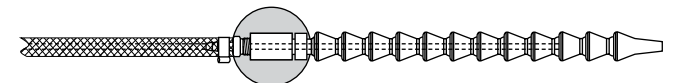

## Specialty Sawing Nozzles:

N-Nozzle, V-Nozzle, C-Nozzle, R-Nozzle: use Loc-Line nozzle instructions.  
CM-Nozzle, CL-Nozzle: use copper/stainless steel nozzle instructions.

\*NOTE: A lubricant line that is longer or shorter than recommended will result in poor, inaccurate lubricant spray and decrease the applicator's effectiveness.

# INSTALLING

Mounting: Accu-Lube Box and Custom Applicators are mounted permanently onto the machine. Optional magnets mounts are available for 1-2 pump applicators.

1. Attach the applicator to the machine, make sure that it is as level as possible.
2. Position and attached the nozzles following the instructions below.
3. Fill the reservoir (Fig. 1 #1) with lubricant. Refer to warranty information on page 13.
4. *Electric solenoid applicators only:* At this point a licensed electrician should set-up the electric solenoid control.
5. Make sure the applicator is off, then the attach air supply to the air inlet (Fig. 1 #11).  
NOTE: If excessive oil, mist, or dirt is present in the air supply an optional coalescing filter is highly recommended (see pages 12-13 for parts information).

## NOZZLE POSITIONING

Nozzle placement is extremely important to effective Minimum Quantity Lubrication; they must be positioned so lubricant is applied to the cutting edge of the tool BEFORE the cut is made (see Fig. 2).

For many machining operations multiple nozzles are recommended for optimal lubrication. Consult your Accu-Lube Sales Representative or the factory for recommendations.

### Specialty Sawing Nozzles:

#### *Band Saw Nozzles; N-Nozzle, RL-Nozzle:*

1. Position the nozzle over the band saw blade and attach to the leading guide arm before the cutting point (see Fig. 2).
2. Make sure the nozzle is  $\frac{1}{2}$ " to  $\frac{3}{4}$ " above the bottom of the blade; the lubricant stream should form a  $45^\circ$  angle with the cutting edge (see Fig. 3). Test the stream position with a piece of paper (see Step 2 of Operations, page 7).

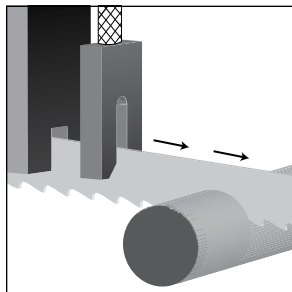

Figure 2.

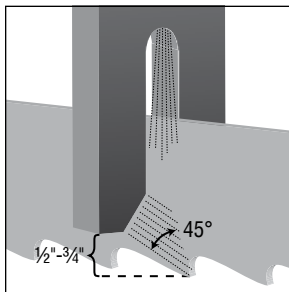

Figure 3.

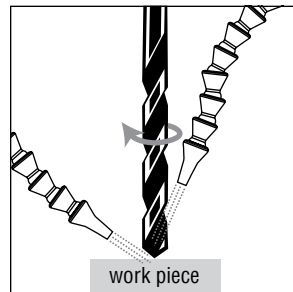

Figure 4.

#### *Band Saw Nozzle; V-Nozzle:*

1. Mount the nozzle on the door near the wheel or on the back side of the machine so that the nozzle faces into the teeth of the blade.

#### *Circular Saw Nozzles; C-Nozzle, CM-Nozzle, CL-Nozzle:*

1. *C-Nozzle only:* If the saw has a covering use the mounting bracket as a template to cut a hole in the covering for the nozzle to go through, then slide the main body of the nozzle through the bracket and the hole in the covering.
2. Mount the bracket where it won't obstruct the movement of the saw.  
NOTE: The C-Nozzle comes with its own mounting bracket but the CM-Nozzle and CL-Nozzle will need a mounting bracket.
3. Position the nozzle within 1" of the blade. Make sure that the lubricant spray evenly covers the gullet and both sides of the blade.

### Standard Nozzles

#### *Copper, stainless steel, Loc-Line:*

1. Position the nozzle less than 1" from the cutting tool making sure it is aimed towards the cutting edge (see Fig. 4).
2. If the machine has moving parts make sure they don't interfere with the nozzle.

## OPERATING

All Accu-Lube pumps are primed and tested before shipping, however if the prime is lost see page 10 for instructions on re-priming the pump before beginning Step 1.

1. Make sure the air supply is connected and then turn the applicator on.
2. Check the lubricant flow by holding a piece of paper where the work piece will be for a minute then remove the paper, there should be a moist circle of lubricant roughly 1" (2.5 cm) in diameter, about the size of a quarter. The paper should be damp but not soaked through.  
NOTE: If the paper is soaked through the lubricant control is set too high.
3. Adjust the airflow valve (Fig. 1 #5) on each pump, turn counterclockwise to increase air flow and clockwise to decrease the flow. The airflow should be just high enough to move the lubricant to the cutting edge.  
NOTE: Misting lubricant is often an indication that the airflow is too high.
4. Set the frequency generator (Fig. 1 #12), see instructions on page 10.
5. Set the lubricant control (Fig. 1 #7), see instructions on pages 8-9.
6. Run the applicator for a few minutes and make sure flow of lubricant is steady and uninterrupted. Repeat Step 2 and check spray pattern.
7. Make a test cut and then check the temperature of the tool and work piece:
  - The tool should be at room temperature +  $15^\circ\text{F}$  ( $8^\circ\text{C}$ ).
  - Work piece should be slightly warmer than the tool.
  - Chips should be hot. **WARNING:** Do not touch chips!

# SETTING THE LUBRICANT CONTROL

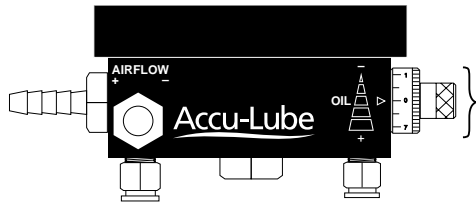

Figure 5. Lubricant Control Side View

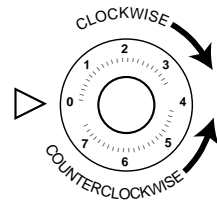

Figure 6. Lubricant Control Front View

The lubricant control is the secondary lubrication control. It is used to fine-tuning the amount of lubricant in each pump cycle.

To set the lubricant control for general operations see Standard Operation Setting below, for more detailed settings see Operation-Specific Settings on the next page.

Before the control can be set the pump must first be set to the Zero Point:

1. **Stop Point:** Turn the lubricant control clockwise as far as it will go, the dial will most likely stop around 3 or 6.  
NOTE: Never leave the control at this setting because lubricant will seep out of the applicator, even when the applicator isn't in operation.

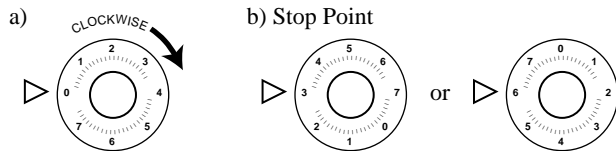

2. **Zero Point:** Turn the lubricant control counterclockwise back to 0.

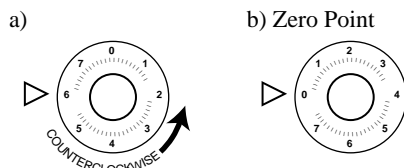

## Standard Operation Setting:

Start at the Zero Point and turn the control counterclockwise 1 full revolution, continue turning until the control is set at 6.

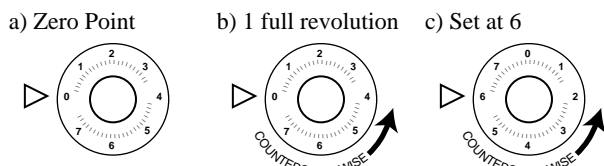

## Operation-Specific Settings:

### Circular Sawing

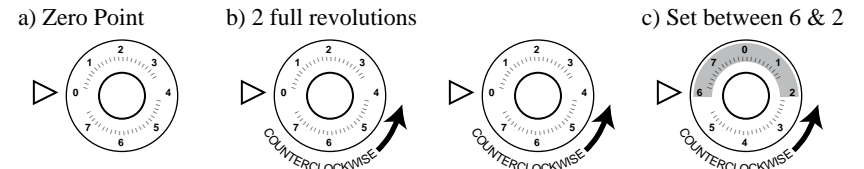

### Band Sawing

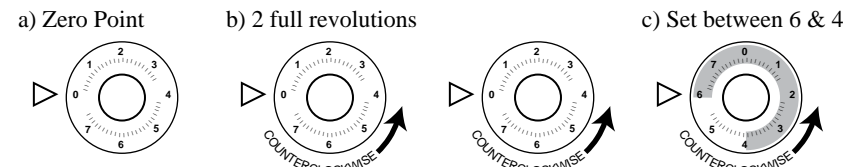

### Broaching

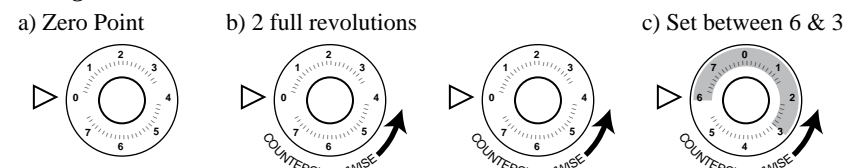

### Milling

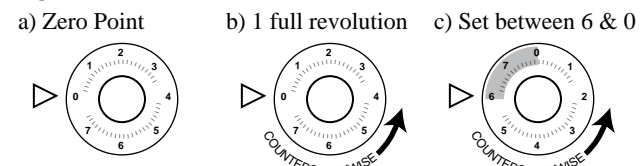

### Drilling & Tapping

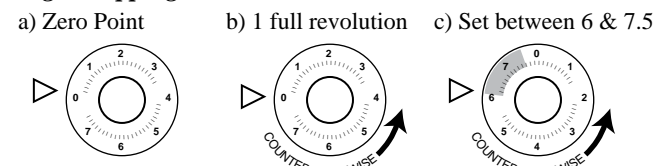

### Grinding

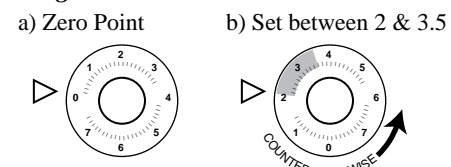

NOTE: If these guidelines aren't working for your operation try adjusting the amount of lubricant and/or the frequency generator (see page 10). You can also contact your Accu-Lube Sales Representative for Technical Support.

## SETTING THE FREQUENCY GENERATOR

The frequency generator controls the pump cycle and is the primary lubrication control. It is used to make major lubricant adjustments, fine tuning is done with the lubricant control.

1. With a stop watch determine the length of the pump cycle in seconds. Each pump cycle consists of two strokes, a back stroke and a forward stroke.
2. Use a small flat screwdriver to adjust the frequency generator, counterclockwise increases the cycle speed and clockwise decreases the speed.
3. With the stop watch continue to monitor the pump cycle until the desired cycle rate is reached.

NOTE: Use the chart below as a ROUGH guideline. Contact the factory or your Accu-Lube Sales Representative for more detailed recommendations.

Application	Cycle time (sec.)	Cycles per min.	Fluid used* (oz.)
Circular sawing	1-4	15-60	1.0-2.8
Band sawing	0.5-4	15-120	1.0-3.3
Broaching	0.5-4	15-120	1.0-3.0
Milling	2-4	15-30	1.0-2.5
Drilling	0.5-4	15-120	1.2
Tapping	0.5-4	15-120	1.2
Grinding	2-5	12-30	0.2-0.4

\* Daily fluid use amount per nozzle during an eight-hour shift.

## RE-PRIMING THE PUMP

1. Make sure the applicator is turned off with the air supply disconnected and the reservoir is filled with lubricant.
2. Turn the lubricant control counterclockwise as far as it will go.  
NOTE: This is the maximum setting and should ONLY be used during priming.
3. Attach the air supply and turn the applicator on.
4. Set the frequency generator to cycle 3 strokes every 1 second (180 cycles per minute).
5. Let the applicator cycle until fluid begins to flow through the lubricant line and out the tip of the nozzle.
6. Once the pump is primed, re-set the frequency generator to operating settings.

NOTE: This process should only take a few minutes, if the applicator has cycled for more than five minutes without any progress refer to Troubleshooting on page 14 for additional help.

## REPLACING THE HOSE ASSEMBLY

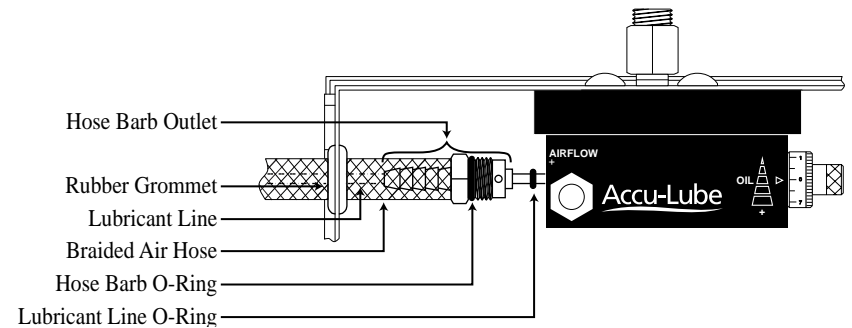

Refer to pages 12-13 for replacement parts information, make sure you have all the necessary components before starting to replace the hose assembly.

1. Cut the old hose assembly (braided air hose & lubricant line) off just past the end of the hose barb outlet and then carefully pull or cut the remaining air hose off the barb.
2. Unscrew the hose barb outlet from the pump.
3. Remove the o-ring from the lubricant line and set it to the side.
4. Remove the remaining lubricant line from the hose barb outlet.
5. Cut the new hose assembly to the appropriate length.
6. Thread the new lubricant line through the grommet and into the hose barb outlet until 1/4" of the line is visible on the inner side.
7. Put the o-ring on the inner end of the lubricant line.
8. Screw the hose barb outlet back into the pump being careful not to over-tighten the hose barb outlet. At the same time, gently feed the lubricant line through the grommet and into the pump while screwing in the hose barb outlet.

NOTE: If the hose barb is over-tightened it will compress the o-ring round the lubricant line and constrict the flow of lubricant.

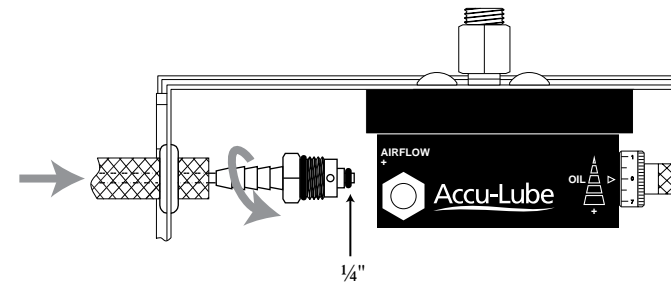

9. Once the hose barb outlet is secured gently pull the lubricant line, if the line is correctly installed it will not come out when pulled.
10. Thread the new air hose over the new lubricant line and secure the air hose over the end of the hose barb outlet.

# REPLACEMENT PARTS

For more information on replacement parts contact your Accu-Lube Sales Representative or visit [www.rocolnorthamerica.com](http://www.rocolnorthamerica.com).

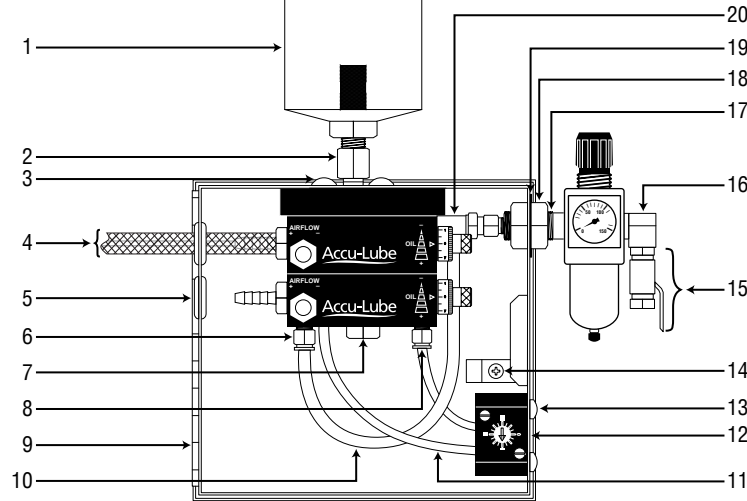

## Part # Description

1	9380	10 oz. reservoir (2 1/8" x 5 3/16", 1/4" NPT)
	9381	1 qt. reservoir (4 1/2" x 7 3/4", 1/4" NPT)
	9382	1/2 gal. reservoir (5 1/2" x 9 1/16", 1/4" NPT)
	9384	1 gal. reservoir (5 1/2" x 14 1/16", 1/4" NPT)
	9383	1 qt. reservoir w/low-level switch
	9386	1 gal. reservoir w/low-level switch
2	9380	Reservoir extension
3	9430A	1/4-20 x 3/8 THMS (screw)
4	90050	Hose assembly*, 12 ft.
	90051	Hose assembly*, 20 ft.
	90052	Hose assembly*, 30 ft.
	90053	Hose assembly*, 45 ft.
	90054	Hose assembly*, 60 ft.
		* Braided air hose + Lubricant line
	9363	Braided air hose (sold by the ft.)
	9360	Lubricant line (sold by the ft.)
5	9637	Rubber grommet
6	9343	Quick release (1/4" x 1/8" NPT)
7	9487	Plug

## Part # Description

8	9344	Quick release (5/32" x 1/8" NPT)
9	9403	Steel security box (1-2 nozzles)
	9404	Steel security box (3-4 nozzles)
	9405	Steel security box (5-8 nozzles)
	9406	Steel security box (9-12 nozzles)
10	9362	Black poly hose 1/4" OD (sold by the ft.)
11	9361	Black poly hose 5/32" OD (sold by the ft.)
12	9707	Frequency generator and base plate
	9460	Frequency generator
	9416	Base plate for frequency generator
13	9432	12-24 x 1/2 phil (screw)
14	9433	8 x 1/2 pan phil s/m (screw)
15	9399	Shut-off valve (1/4" male x 1/4" female)
	9483	Shut-off valve (3/8" female x 3/8" female)
16	9266	Elbow - street 1/4
17	9241	1/4 close nipple
18	9230	1/4 NPT bulkhead fitting
19	9597	1/4 bulkhead washer
20	9331	Male run tee, 1/4" x 5/32" x 1/4" NPT

# REPLACEMENT PARTS CONTINUED...

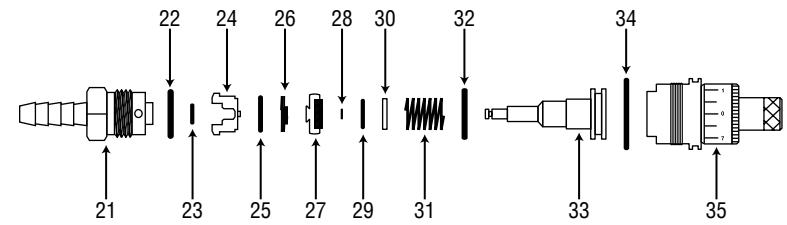

Not shown:

Part #	Description
79120	Magnetic mount (nut & bolt included)
9402	Coalescing filter, 1/4" (1-4 nozzle units)
9374	Coalescing filter, 3/8"
9396	Air filter w/gauge (1-4 nozzle units)
9398	Air filter w/gauge (5+ nozzle units)
9046	Frequency generator repair kit
9518	Electric solenoid, 110 VAC (1/4" NPT)
9522	Electric solenoid, 220 VAC (1/4" NPT)
9526	Electric solenoid, 440 VAC
9524	Electric solenoid, 100 VAC (stacking)
9519	Electric solenoid, 200 VAC
9516	Electric solenoid, 24 VDC (1/4" NPT)
9202	Complete lock assembly

## Part # Description

Part #	Description	Qty.	Qty.	Qty.
21	9496	Hose barb, 1/4" x 1/8" NPT		1
22	9474	O-ring barb seal	1	1
23	9490A	O-ring for lubricant line	2	2
24	N/A	Lubricant line sleeve		
25		O-ring (.301 ID x .07)	3	3
26		Conical evac spring	1	1
27		Evac valve	1	1
28		O-ring (.065 ID x .035)	1	1
29		Same as #23		
30	N/A	Retaining ring for o-ring		
31		Return spring	1	1
32		U-cup, viton (.5 ID x 1/16)	1	1
33		1/8" stainless steel piston		1
34		O-ring, viton (.75 ID x .62)	1	1
35	N/A	Lubricant control		

Pump Repair Kit (#9668)  
Pump Repair Kit w/Piston (#9065)  
Hose Barb Repair Kit (#309040)

Parts 24, 30, and 35 can not be replaced  
Parts 25-28 and 31-34 are only available in kits

# WARRANTY

All Accu-Lube precision pump applicators are backed with a Two-Year Limited Warranty against defects in workmanship and/or materials. Warranty applies only when used under normal operating conditions.

Any part which is returned to ITW ROCOL North America – Accu-Lube that is determined to be defective in workmanship and/or materials will be repaired or replaced by ITW ROCOL North America. A minimum labor fee of one hour will be charged. Additional shipping charges may apply.

All Warranties, expressed and implied, are null and void if the equipment is subject to improper installation/application, misuse, neglect, and/or accident or if a lubricant other than Accu-Lube brand lubricant is used in the warranted equipment.

For more information on warranties, service, and repairs contact Customer Service. Returned equipment will not be accepted without prior approval and a Return Merchandise Authorization (RMA) form.





# User's Manual

*Installation & Operating Instructions*

## PRECISION PUMP APPLICATOR

***ITW* ROCOL® North America**

3650 West Lake Ave, Glenview, IL 60026

Toll Free: (800)452-5823

Tel: (847) 657-5278

Fax: (847) 657-4897

info@itwrocolna.com

www.itwrocolna.com



*Revised 06/2011*