

Universal Wheel Skimmer



INSTRUCTIONS for 78034 & 78035

COMPONENTS

- A. 120V, 50/60 Hz, 0.6 amp single phase motor with injection molded frame
- B. Wheel
- C. Wheel hub
- D. 10-32 x 1/4" cup point set screw
- E. 8-32 x 1/2" pan phil screws (2)
- F. 10-32 x 3/8" stph screws (4)
- G. Plastic wheel wipers (2)

WARNINGS

- Skimmer should be used only to remove tramp oil from machine sumps and parts washers.
- Keep motor away from liquids. Do not submerge motor in liquid.
- Protect motor from spray.
- Motor must have a grounded fault circuit interrupt.
- If motor becomes submerged, make sure the electrical cord is disconnected before retrieving motor.
- Skimmer is intended for intermittent use only.

SKEMATICS

12" Universal Wheel Skimmer (#78034)

TOP VIEW

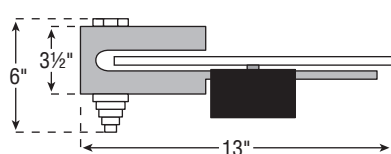

SIDE VIEW

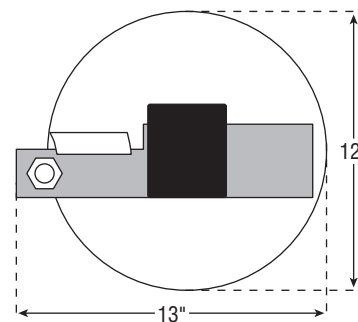

18" Universal Wheel Skimmer (#78035)

TOP VIEW

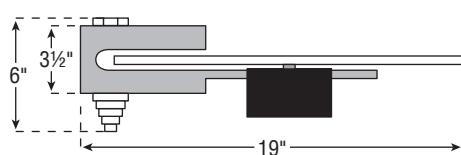

SIDE VIEW

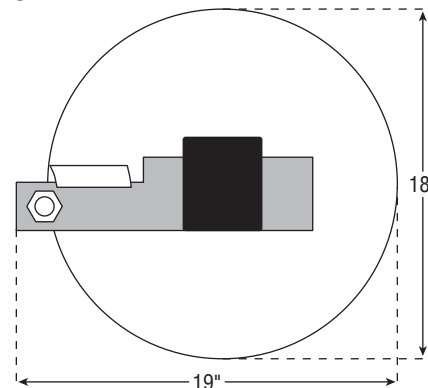

Universal Wheel Skimmer INSTRUCTIONS for 78034 & 78035

SET-UP

1. Insert D into the side of the wheel hub using a 3/32" allen wrench.
2. Slide the wheel hub onto the motor shaft so that the flat side of the hub points away from the motor.
3. Attach the hub to the motor shaft by tighten D with the allen wrench.
4. Attach the wheel to the hub using E.
5. Use F to attach the wheel wipers to the frame on both sides of the wheel.

MOUNTING

Skimmer can be mounted to the sump/washer tank or tank cover, supported by legs over the tank, or suspended by beams across the surface of the tank. Hardware not included.

1. Position the skimmer so that 1-3" of the wheel is submerged in the liquid to be cleaned.
2. Mount the skimmer securely in place.
3. Put a waste oil bucket or pan underneath the end of the bidirectional oil drain, the collected tramp oil should drain easily into the waste container. Put a hose over the oil drain to direct oil to a container further away.

OPERATING

For best results the machine should be turned off and liquid in the tank should not circulate during skimmer operation.

1. Once the skimmer is properly mounted, plug the unit into electrical source. Make sure the skimmer is grounded.
2. Under normal conditions the skimmer should run in 10-15 minute intervals, for a total of approximately 1-2 hours a day depending on amount of oil to be skimmed. For the most effective oil removal a timer is recommended to automatically turn the skimmer on and off at regular intervals

NOTE: The motor is equipped with an internal overload which will shut the motor off if it over heats. The motor automatically resets itself after cooling down to normal operating temperature range.

WHEEL CONVERSION

1. Remove the old wheel from the hub, do not remove the hub from the motor shaft.
2. Remove the motor from the skimmer frame by unscrewing the four screws that hold it in place.
3. 12" to 18" conversion: Reattach the motor to the predrilled holes at the end of the skimmer frame.
18" to 12" conversion: Reattach the motor to the predrilled holes in the middle of the frame.
4. Attach the new wheel to the hub.

WARRANTY

Skimmer motors come with a One-Year Limited Warranty from the date of purchase against defects in workmanship and materials. Warranty is void if the unit is subject to improper installation/application, misuse, neglect, or accident. For additional information contact Customer Service at 800-452-5823 x2. Returned units will not be accepted with out prior approval.

REPLACEMENT PARTS

Part No.	Description
78075	Replacement motor, 120V, 50/60 Hz, 0.6 amp single phase
78055	12" Replacement wheel and hub
78065	18" Replacement wheel and hub
78085	Wiper blades (qty. 2)

TW ROCOL® North America

3624 West Lake Avenue, Glenview, Illinois 60026

Tel: (800) 452-5823 or (847) 657-5278

Fax: (800) 952-5823 or (847) 657-4897

info@rocolnorthamerica.com

www.rocolnorthamerica.com